

KOMATSU®

WA380-5

HORSEPOWER
Gross: 152 kW 203 HP / 2000 rpm
Net: 140 kW 190 HP / 2000 rpm

OPERATING WEIGHT
16250 – 16510 kg
35,825 – 36,395 lb

BUCKET CAPACITY
2.7 – 4.0 m³ 3.5 – 5.2 yd³

WA
380

W
H
E
E
L
L
O
A
D
E
R



Photo may include optional equipment.

WA380-5 Wheel Loader

WALK-AROUND

High Productivity & Low Fuel Consumption

- Powerful engine
- Ultra-low fuel consumption
- Dual-mode engine power select system
- Transmission mode select system
- Dual speed hydraulic system
- Superior dumping clearance and reach
- Long wheelbase and 40 degree articulation

See pages 4 and 5.

Excellent Operator Environment

- Automatic transmission with selectable modes
- Electrically controlled transmission lever
- Fingertip control levers
- Pillar-less large ROPS/FOPS (ISO 3471/ISO 3449) cab
- Easy entry/exit, rear-hinged doors
- Telescopic/tilt steering column

See pages 8 and 9.



Harmony with Environment

- U.S. EPA Tier 2 and EU Stage 2 emissions certified
- Low fuel consumption

See page 4.

Increased Reliability

- Reliable Komatsu designed and manufactured components
- Sturdy main frame
- Maintenance-free, fully hydraulic, wet multiple-disc service and parking brakes
- All hydraulic hoses use flat face O-ring seals
- Cathion electrodeposition process is used to apply primer paint
- Powder coating process is used to apply on main structure
- Sealed connectors for electrical connections

See page 6.

HORSEPOWER
Gross: 152 kW 203 HP / 2000 rpm
Net: 140 kW 190 HP / 2000 rpm

OPERATING WEIGHT
16250 – 16510 kg
35,825 – 36,395 lb

BUCKET CAPACITY
2.7 – 4.0 m³
3.5 – 5.2 yd³



Photo may include optional equipment.

Easy Maintenance

- Equipment management monitoring system
- Reversible radiator fan (Optional)
- Swing-out aftercooler and oil coolers
- Prolonged engine oil change interval
- Ground check for windshield washer tank and coolant tank
- Easy access, gull-wing type engine side doors

See page 7.

PRODUCTIVITY FEATURES

High Productivity and Low Fuel Consumption

Powerful Engine

The high pressure fuel injection in the SAA6D114E-2 engine provides optimum combustion of fuel at both low and high speed/power applications. This engine also provides fast throttle response to match the machine's powerful rim pull and fast hydraulic response.

140 kW 187 HP

This engine is U.S. EPA Tier 2 and EU Stage 2 emissions certified.

Low Fuel Consumption

The fuel consumption is reduced greatly because of the low-noise, high-torque engine and the large-capacity torque converter with maximum efficiency in the low-speed range.

Reduction of Fuel Consumption: 15% (Compared with Dash 3 technology).

Dual-mode Select System

This wheel loader offers two selectable operating modes—Normal and Power. The operator can adjust the machine's performance by flipping a switch.

- **Normal Mode:** This mode provides maximum fuel efficiency for most of general loading.
- **Power Mode:** This mode provides maximum power output for hard digging operation or hill climb.



Transmission Mode Select System

This operator controlled system allows the operator to select manual shifting or three levels of automatic shifting (Low, medium, and high).



- **Manual:** Transmission is fixed to gear speed selected with gear shift lever.
- **Auto. L:** This mode provides smooth gear change and low fuel consumption since gear shifting is performed at relatively low engine speeds, suitable for general excavating and loading.
- **Auto. M:** Gear is shifted at medium engine speeds between those of L and H modes.
- **Auto. H:** This mode provides large rim pull and short cycle time since gear shifting is performed at relatively high engine speeds, suitable for load and carry operation on uphill.

Dual-speed Hydraulic System

Komatsu's dual-speed hydraulic system increases operational efficiency by matching the hydraulic demands to work conditions.

Oil from the switch pump is completely returned to the tank when digging and breaking out, therefore, hydraulic flow to the loader is reduced and pressure is increased. This reduces horsepower demand from the engine and makes the operation more efficient. Kick-down switch signal also controls the oil flow. This technology is greater productivity at the lowest operating cost.

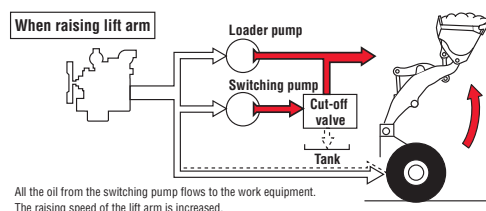
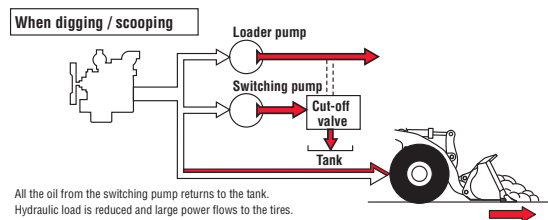



Maximum Dumping Clearance and Reach



The long lift arms provide high dumping clearances and maximum dumping reach. The operator can even level loads on the body of a dump truck easily and efficiently.

Dumping Clearance: 2885 mm 9'6"

Dumping Reach: 1210 mm 4'0"

3.3 m³ 4.3 yd³ bucket with Bolt-On Cutting edge (B.O.C.)

Long Wheelbase/Articulation Angle of 40°

The widest tread in class and the long wheelbase provide improved machine stability in both longitudinal and lateral directions. Since the articulation angle is 40°, the operator can work efficiently even in the tightest job sites.

Tread	2160 mm 7'1"
Wheelbase	3300 mm 10'10"
Minimum Turning Radius (Center of Outside Tire)	5620 mm 18'5"

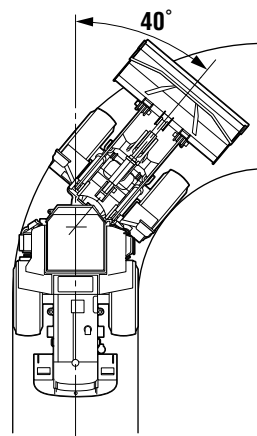

INCREASED RELIABILITY

Komatsu Components

Komatsu manufactures the engine, torque converter, transmission, hydraulic units, electric parts, and even each bolt on this wheel loader. Komatsu loaders are manufactured with an integrated production system under a strict quality control system.

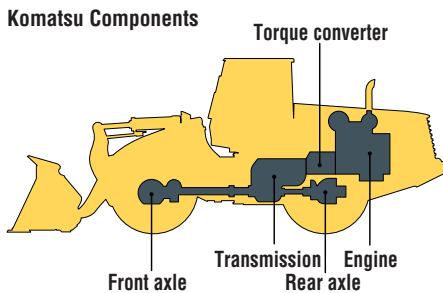

High-rigidity Frames

The front and rear frames have high rigidity to bear twisting and bending loads applied repeatedly to the loader body. Both upper and lower center pivot bearings are tapered roller bearings having high durability. The structure is similar to those of large-sized loaders and the reinforced loader linkage also ensures high rigidity.

Wet Multiple-disc Brakes and Fully Hydraulic Braking System mean lower maintenance costs and higher reliability. Wet multiple-disc brakes are fully sealed. Contaminants are kept out, reducing wear and resulting maintenance. Brakes require no adjustments for wear, meaning even lower maintenance. The parking brake is also an adjustment-free, wet multiple-disc for high reliability and long life.

Added reliability is designed into the braking system by the use of two independent hydraulic circuits. Provides hydraulic backup should one of the circuits fail.

Fully hydraulic brakes mean no air system to bleed, or the condensation of water in the system that can lead to contamination, corrosion, and freezing.

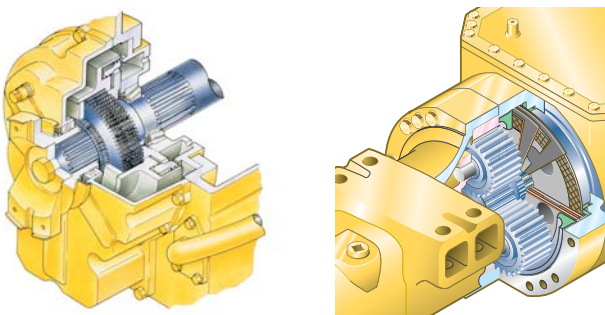

Flat Face-to-face O-ring Seals

Flat face-to-face O-ring seals are used to securely seal all hydraulic hose connections and to prevent oil leakage. In addition, buffer rings are installed to the head side of the all-hydraulic cylinders to lower the load on the rod seals and maximize the reliability.

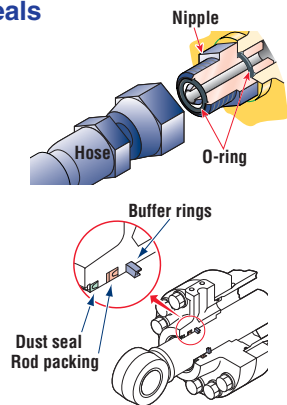

Cathion Electrodeposition Primer Paint/ Powder Coating Final Paint

Cathion electrodeposition paint is applied as a primer paint and powder coating is applied as topcoat to the exterior metal sheet parts. This process results in a beautiful rust-free machine, even in the most severe environments. Some external parts are made of plastic providing long life and high impact resistance.

Sealed Connectors

Main harnesses and controller connectors are equipped with sealed connectors providing high reliability, water resistance and dust resistance.

EASY MAINTENANCE

Equipment Management Monitoring System

Monitor is mounted in front of the operator for easy view, allowing the operator to easily check gauges and warning lights.



A specially designed two-spoke steering wheel allows the operator to easily see the instrument panel.

Maintenance control and troubleshooting functions

- **Action code display function.** If the loader has any troubles, the monitor displays action details on the character display at the center bottom of the monitor.
- **Monitor function.** Controller monitors engine oil level, pressure, coolant temperature, air cleaner clogging, etc. If controller finds abnormalities, all of these are displayed on Liquid Crystal Display (LCD).
- **Replacement time notice function.** Monitor informs replacement time of oil and filters on LCD when it reaches replacement intervals.
- **Trouble data memory function.** Monitor stores abnormalities for effective troubleshooting.

Reversible Cooling Fan (Optional) and Swing-out Cooler Elements



If the machine is operating in adverse conditions, the operator can reverse the hydraulic cooling fan from inside the cab by turning on a switch on the control panel. The coolers can also swing out for easy cleaning.



Gull-wing Type Engine Side Doors Open Wide

The operator can open and close each gull-wing type engine side door easily with the assistance of a gas spring to perform daily service checks from the ground.

Lengthened Maintenance Interval

Lengthened engine oil replacement interval:
250 H → 500 H

Lengthened drive shaft greasing interval:
1,000 H → 4,000 H

OPERATOR ENVIRONMENT

Easy Operation

Automatic Transmission with Electronically Controlled Modulation Valve

Automatic transmission with electronically controlled modulation valve automatically selects the proper gear speed based on travel speed, engine speed, and other travel conditions. The electronically controlled modulation valve system engages the clutch smoothly to prevent lags and shocks when shifting. This system provides efficient machine operation and a comfortable ride.

- **Kick-down**

switch: Consider this valuable feature for added productivity. With the touch of a finger, the kick-down switch

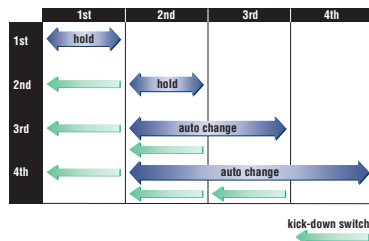

automatically downshifts from second to first when beginning the digging cycle. It automatically upshifts from first to second when the direction control lever is placed in reverse. This results in increased rim pull for better bucket penetration and reduced cycle times for higher productivity.

- **Hold switch:** Auto shift is selected and if the operator turns on this switch when the lever is at the 3rd or 4th gear speed position, the transmission is fixed to that gear speed.

Electronically Controlled Transmission Lever



Easy shifting and directional changes with Komatsu two-lever electronic shifting. Change direction or shift gears with a touch of the fingers without removing the shifting hand from the steering

wheel. Solid state electronics and conveniently located direction and gear shift controls make this possible. Automatic shifts in ranges two through four keep production high and manual shifting at a minimum.

Variable Transmission Cut-off

The operator can adjust the transmission cut-off connected to the left brake pedal with the switch near the operator's seat to set the brake/cut-off point for easier operation and higher operating performance in variable operating conditions.

- High cut-off pressure for digging operations.
- Low cut-off pressure for truck-loading operations.

Telescopic/Tilt Steering Column

The operator can tilt and telescope the steering column to provide a comfortable working position.



Fingertip Work Equipment Control Lever

Pressure Proportional Control (PPC) levers are used for the work equipment. The operator can easily operate the work equipment with fingertip control, reducing operator fatigue and increasing controllability.



Comfortable Operation

Low-noise Design

The large cab is mounted with Komatsu's unique ROPS/FOPS (ISO 3471/ISO 3449) viscous mounts. The low-noise engine, hydraulically driven fan, and hydraulic pumps are mounted with rubber cushions, and the cab sealing is improved to provide a quiet, low-vibration, dustproof with pressurizing, and comfortable operating environment.



Pillar-less Large Cab

A wide pillar-less flat glass provides excellent front visibility.



The wiper arm covers a large area to provide great visibility even on rainy days.

The cab area is the largest in its class providing maximum space for the operator.

Rear-hinged Full Open Cab Door

The cab door hinges are installed to the rear side of the cab providing a large opening angle for the operator to enter and exit. The steps are designed like a staircase, so that the operator can get on and off the cab easily.



Secondary Brake

If the brake oil pressure drops, the warning lamp flashes and the warning buzzer sounds intermittently. If the brake pressure drops lower, the parking brake is applied providing a double safety system.



SPECIFICATIONS



ENGINE

ModelKomatsu SAA6D114E-2
 TypeWater-cooled, 4-cycle
 AspirationTurbocharged
 Number of cylinders6
 Bore x stroke**114 mm x 135 mm** 4.49" x 5.31"
 Piston displacement**8.27 ltr** 505 in³
 Performance:
 Horsepower
 SAE J1995Gross **152 kW** 203 HP
 ISO 9249/SAE J1349Net **140 kW** 190 HP
 Rated rpm2000 rpm
 Fuel systemDirect injection
 GovernorMechanical, all-speed control
 Lubrication system:
 Lubrication methodGear pump, force-lubrication
 FilterFull-flow type
 Air cleanerDry type with double elements and dust evacuator, plus dust indicator

U.S. EPA Tier 2 and EU Stage 2 emissions certified.



TRANSMISSION

Torque converter:
 Type3-element, single-stage, single-phase
 Transmission:
 TypeFull-powershift, countershaft type
 Travel speed: **km/h** mph
 Measured with 20.5-25 tires

	1st		2nd		3rd		4th	
Forward	6.3	3.9	11.4	7.1	20.2	12.6	31.5	19.6
Reverse	6.7	4.2	11.8	7.3	21.0	13.0	32.5	20.2

Measured with 23.5-25 tires

	1st		2nd		3rd		4th	
Forward	6.8	4.2	12.3	7.6	21.4	13.3	34.0	21.1
Reverse	7.3	4.5	12.8	8.0	22.6	14.0	35.0	21.7



AXLES AND FINAL DRIVES

Drive systemFour-wheel drive
 FrontFixed, semi-floating
 RearCenter-pin support, semi-floating, 26° total oscillation
 Reduction gearSpiral bevel gear
 Differential gearConventional type
 Final reduction gearPlanetary gear, single reduction



BRAKES

Service brakesHydraulically actuated, wet multiple-disc brakes actuate on four wheels
 Parking brakeWet multiple-disc brake
 Secondary brakeParking brake is commonly used



STEERING SYSTEM

TypeArticulated type, full-hydraulic power steering
 Steering angle40° each direction
 Minimum turning radius at the center of outside tire**5620 mm** 18'5"



HYDRAULIC SYSTEM

Steering system:
 Hydraulic pumpGear pump
 Capacity**94 ltr/min** 24.8 U.S. gal/min at rated rpm
 Relief valve setting**160 kgf/cm²** 2,275 psi
 Hydraulic cylinders:
 TypeDouble-acting, piston type
 Number of cylinders2
 Bore x stroke**80 mm x 442 mm** 3.1" x 17.4"
 Loader control:
 Hydraulic pumpGear pump
 Capacity**212 + 94 ltr/min** 56.0 + 24.8 U.S. gal/min at rated rpm
 Relief valve setting**210 kgf/cm²** 3,000 psi
 Hydraulic cylinders:
 TypeDouble-acting, piston type
 Number of cylinders—bore x stroke:
 Boom cylinder**2—160 mm x 713 mm** 6.3" x 28.1"
 Bucket cylinder**1—180 mm x 535 mm** 7.1" x 21.1"
 Control valve2-spool type
 Control positions:
 BoomRaise, hold, lower, and float
 BucketTilt-back, hold, and dump
 Hydraulic cycle time (Rated load in bucket)
 Raise5.7 sec
 Dump1.4 sec
 Lower (Empty)3.3 sec



SERVICE REFILL CAPACITIES

Cooling system**36 ltr** 9.5 U.S. gal
 Fuel tank**300 ltr** 79.3 U.S. gal
 Engine**32 ltr** 8.5 U.S. gal
 Hydraulic system**129 ltr** 34.1 U.S. gal
 Axle (Each front and rear)**38 ltr** 10.0 U.S. gal
 Torque converter and transmission**54 ltr** 14.3 U.S. gal



BUCKET SELECTION GUIDE

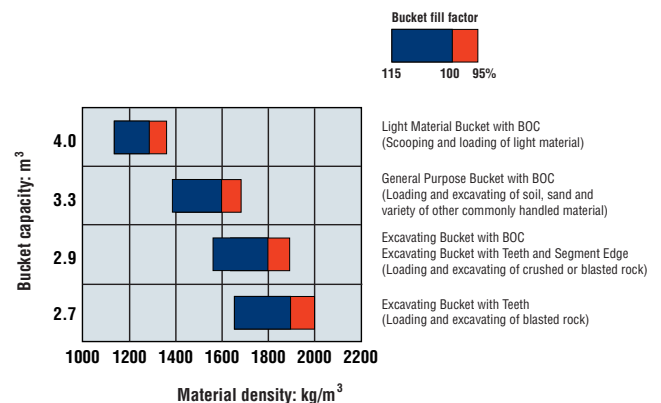



DIMENSIONS

Measured with 20.5-25-16PR (L-3) tires

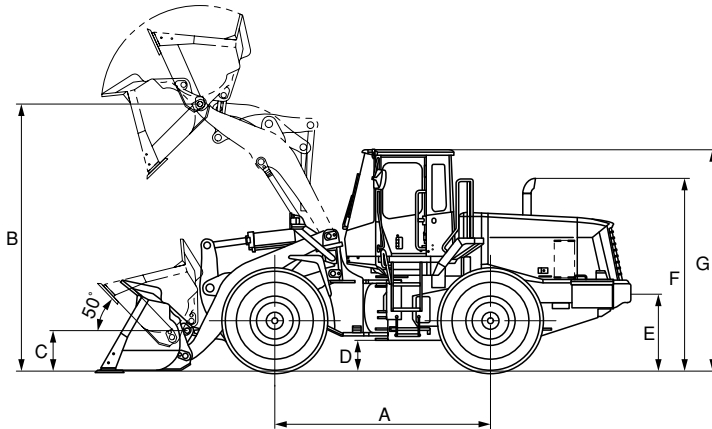

	Tread	2160 mm	7'1"
	Width over tires	2695 mm	8'10"
A	Wheelbase	3300 mm	10'10"
B	Hinge pin height, max. height	4030 mm	13'3"
C	Hinge pin height, carry position	520 mm	1'8"
D	Ground clearance	390 mm	1'3"
E	Hitch height	1085 mm	3'7"
F	Overall height, top of the stack	2885 mm	9'6"
G	Overall height, ROPS (ISO 3471) cab	3315 mm	10'11"

	General Purpose Buckets			Excavating Buckets			Light Material Bucket
	B.O.C.	Teeth and Segments	Teeth	B.O.C.	Teeth and Segments	Teeth	B.O.C.
Bucket Capacity: Heaped	3.3 m ³ 4.3 yd ³	3.3 m ³ 4.3 yd ³	3.1 m ³ 4.1 yd ³	2.9 m ³ 3.8 yd ³	2.9 m ³ 3.8 yd ³	2.7 m ³ 3.5 yd ³	4.0 m ³ 5.2 yd ³
Struck	2.9 m ³ 3.8 yd ³	2.9 m ³ 3.8 yd ³	2.7 m ³ 3.5 yd ³	2.4 m ³ 3.1 yd ³	2.4 m ³ 3.1 yd ³	2.3 m ³ 3.0 yd ³	3.4 m ³ 4.4 yd ³
Bucket Width	2905 mm 9'6"	2925 mm 9'7"	2925 mm 9'7"	2905 mm 9'6"	2925 mm 9'7"	2925 mm 9'7"	2905 mm 9'6"
Bucket Weight	1645 kg 3,627 lb	1690 kg 3,726 lb	1570 kg 3,461 lb	1720 kg 3,792 lb	1765 kg 3,891 lb	1645 kg 3,627 lb	1835 kg 4,045 lb
Dumping Clearance, Max. Height and 45° Dump Angle*	2885 mm 9'6"	2755 mm 9'0"	2755 mm 9'0"	2960 mm 9'9"	2840 mm 9'4"	2840 mm 9'4"	2790 mm 9'2"
Reach at Max. Height and 45° Dump Angle *	1210 mm 4'0"	1305 mm 4'3"	1305 mm 4'3"	1125 mm 3'8"	1225 mm 4'0"	1225 mm 4'0"	1295 mm 4'3"
Reach at 2130 mm 7' Clearance and 45° Dump Angle	1760 mm 5'9"	1790 mm 5'10"	1790 mm 5'10"	1720 mm 5'8"	1755 mm 5'9"	1755 mm 5'9"	1800 mm 5'11"
Reach with Arm Horizontal and Bucket Level	2650 mm 8'8"	2810 mm 9'3"	2810 mm 9'3"	2535 mm 8'4"	2695 mm 8'10"	2695 mm 8'10"	2775 mm 9'1"
Operating Height (Fully Raised)	5520 mm 18'1"	5520 mm 18'1"	5520 mm 18'1"	5405 mm 17'9"	5405 mm 17'9"	5405 mm 17'9"	5655 mm 18'7"
Overall Length	8195 mm 26'11"	8350 mm 27'5"	8350 mm 27'5"	8080 mm 26'6"	8235 mm 27'0"	8235 mm 27'0"	8320 mm 27'4"
Loader Clearance Circle (Bucket at Carry, Outside Corner of Bucket)	13160 mm 43'2"	13270 mm 43'6"	13270 mm 43'6"	13090 mm 42'11"	13200 mm 43'4"	13200 mm 43'4"	13220 mm 43'4"
Digging Depth: 0°	125 mm 4.9"	140 mm 5.5"	140 mm 5.5"	125 mm 4.9"	140 mm 5.5"	140 mm 5.5"	125 mm 4.9"
10°	360 mm 1'2"	400 mm 1'4"	400 mm 1'4"	335 mm 1'1"	380 mm 1'3"	380 mm 1'3"	380 mm 1'3"
Static Tipping Load: Straight	12970 kg 28,590 lb	12925 kg 28,495 lb	13045 kg 28,760 lb	12895 kg 28,430 lb	12850 kg 28,330 lb	12970 kg 28,595 lb	13160 kg 29,012 lb
40° Full Turn	11275 kg 24,855 lb	11230 kg 24,758 lb	11350 kg 25,020 lb	11220 kg 24,735 lb	11180 kg 24,645 lb	11285 kg 24,880 lb	11450 kg 25,240 lb
Breakout Force	148 kN 15080 kgf 33,245 lb	160 kN 16315 kgf 35,968 lb	160 kN 16315 kgf 35,968 lb	163 kN 16621 kgf 36,642 lb	168 kN 17131 kgf 37,766 lb	177 kN 18048 kgf 39,789 lb	135 kN 13766 kgf 30,348 lb
Operating Weight	16320 kg 35,980 lb	16370 kg 36,090 lb	16250 kg 35,825 lb	16400 kg 36,155 lb	16440 kg 36,245 lb	16320 kg 35,980 lb	16510 kg 36,395 lb

B.O.C. : Bolt-On Cutting edge

* At the end of tooth or B.O.C.

All dimensions, weights, and performance values based on SAE J732c and J742b standards.

Static tipping load and operating weight shown include lubricant, coolant, full fuel tank, ROPS (ISO 3471) cab, air conditioner (A/C) and operator. Machine stability and operating weight affected by counterweight, tire size, and other attachments.

Apply the following weight changes to operating weight and static tipping load.



WEIGHT CHANGES

Tires or Attachments	Operating Weight		Tipping Load Straight		Tipping Load Full Turn		Width Over Tires		Ground Clearance		Change in Vertical Dimensions	
	kg	lb	kg	lb	kg	lb	mm	ft in	mm	ft in	mm	ft in
20.5-25-16PR(L-3)	0	0	0	0	0	0	2695	8'10"	390	1'3"	0	0
23.5-25-16PR(L-3)	+1080	+2381	+740	+1632	+650	+1433	2780	9'1"	460	1'6"	+65	+3"
Remove ROPS (ISO 3471) Cab with A/C	-720	-1,585	-725	-1,600	-630	-1,390	0	0	0	0	0	0
Install ROPS (ISO 3471) Canopy	+430	+950	+410	+905	+360	+795	0	0	0	0	-30	-1"
Install Additional Counterweight	+325	+717	+860	+1,896	+715	+1,577						



STANDARD EQUIPMENT

- 2-spool valve for boom and bucket controls
- Additional fuel filter
- Air conditioner
- Alternator, 60 A
- Auto shift transmission with mode select system
- Back-up alarm
- Back-up lamp
- Batteries, 2 x 12 V/150 Ah
- Boom kick-out
- Bucket positioner
- Counterweight
- Directional signal
- Engine, Komatsu SAA6D114E-2 diesel
- Engine shut-off system, electric
- Floormat
- Front fender
- Lift cylinders and bucket cylinder
- Loader linkage with standard lift arm
- Main monitor panel with equipment management monitoring system
- PPC fingertip control, two levers
- Radiator mask, lattice type
- Rearview mirror
- Rear window washer and wiper
- ROPS/FOPS (ISO 3471/ISO 3449) cab
- Seat belt
- Seat, suspension type with reclining
- Service brakes, wet multiple-disc type
- Starting motor, 24 V/7.5 kW
- Steering wheel, tiltable
- Sun visor
- Swing-out aftercooler and oil cooler
- Tires (20.5-25-16PR (L-3), tubeless) and rims
- Transmission, 4 forward and 4 reverse
- Water separator



OPTIONAL EQUIPMENT

- 3-spool valve
- Additional counterweight
- Air conditioner side louver
- Alternator, 35 A
- AM/FM radio
- Brake cooling system
- Bucket teeth (Bolt-on type)
- Bucket teeth (Tip type)
- Counterweight for log
- Cutting edge (Bolt-on type)
- Deluxe suspension seat
- Electronically controlled suspension system
- Engine pre-cleaner with extension
- High lift arm
- Hydraulic-driven fan with reverse rotation
- KOMTRAX
- Limited slip differential (F&R)
- Log grapple
- Ordinary spare parts
- Power train guard
- Remote grease (Lift arm pivot pin)
- ROPS/FOPS (ISO 3471/ISO 3449) canopy
- Secondary steering (ISO 5010)
- Tool kit
- Vandalism protection kit
- Vinyl suspension seat

www.komatsu.com

Printed in Japan 201506 IP.As

KOMATSU®

CEN00441-02

Materials and specifications are subject to change without notice.
KOMATSU is a trademark of Komatsu Ltd. Japan.